

RAMJET

Mini-MAC[®]

Marathon Apartment Compactor

It's Small, But Powerful!



The **Mini-MAC[®]** – Marathon Apartment Compactor is now smaller than ever! We took our standard RJ-1835 and used cross-cylinder technology to shorten the unit. This allows it to fit in even more applications where space is limited such as small trash rooms of apartment and high-rise buildings.

The **Mini-MAC[®]** features a new device that allows the user to easily connect and ratchet the container from one side!

Our 2 cy. compaction container is mounted on poly clad casters to allow it to be moved to the pick-up area. They can be configured for front or rear load collection vehicles.



Mini-MAC Apartment Compactor shown with chute feed hopper, access door and optional compaction container for front load collection vehicles.



79 5/16" 43 1/2"

Rental & Leasing Programs Available

Specifications: **Model 3A** **Model 5A**

Charge Box Capacity

Mfrs. rating	0.39 cu yd	0.39 cu yd
WASTEC rating	0.28 cu yd	0.28 cu yd
Clear Top Opening	22.5"L x 28"W	22.5"L x 28"W
Capacity Per Hour	37 cu yd	74 cu yd

Performance Characteristics:

Cycle Time	28 sec	14 sec
Minimum Normal Force	13,900 lb	13,900 lb
Minimum Pack-Out Force	16,400 lb	16,400 lb
Min. Normal Ram Face Force	23.2 psi	23.2 psi
Min. Pack-Out Ram Face Force	27.3 psi	27.3 psi
Ram Penetration	4"	4"

Electrical Equipment:

Tri-volt Motor: 208/230/460, 3-phase	3 hp	5 hp
Control Voltage	120 VAC	120 VAC

UL Label Control Box:

Remote Power Unit with controls mounted in the face of the box
 NEMA 3 Type, All circuits fused;
 Standard Controls: Keylock Start/Stop/Reverse;

Hydraulic Equipment:

Hydraulic Pump Capacity	3 gpm	6 gpm
Normal System Pressure	1650 psi	1650 psi
Maximum System Pressure	1950 psi	1950 psi
2 - Hydraulic Cylinders	2.5" Bore, 1.25" Rod	

Weight 1600 lbs 1600 lbs.
 (does not include remote power unit)

RAMJET® Mini-MAC®

Marathon Apartment Compactor

Standard Features:

- ▼ Remote power unit
- ▼ Convenient, single side ratchet
- ▼ **CYCON Life-Xtender®** Cyclic Control System that offers reliable, solid state circuitry eliminating pressure and limit switches
- ▼ Push button controls mounted in the panel box face
- ▼ Hopper with access door and interlock for hand feed or chute feed applications
- ▼ Photoelectric cycle control
- ▼ Full container light
- ▼ Unit is **UL Listed**
- ▼ Single phase power units available

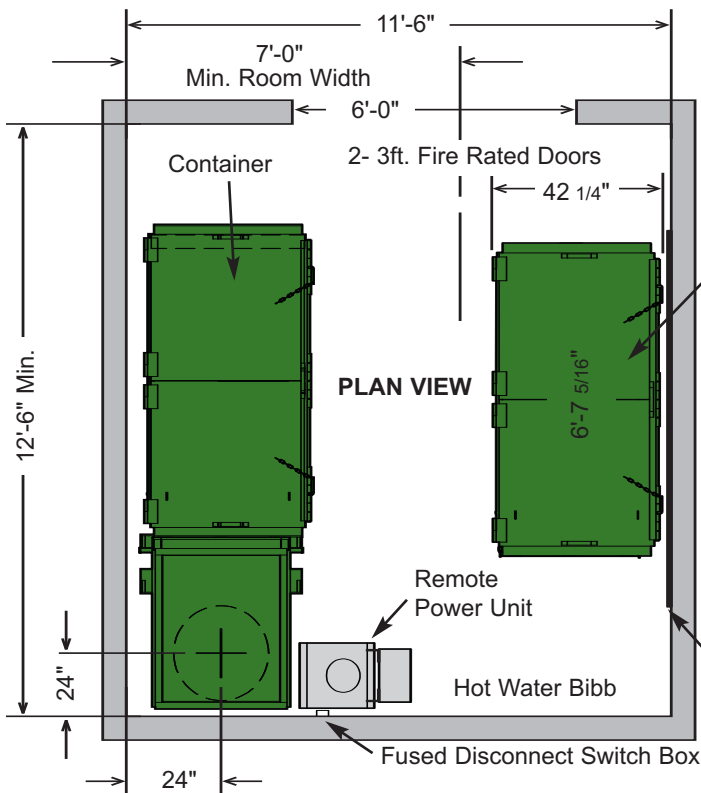

Typical Mini-MAC® -3A Apartment Compactor Configuration with Chute System

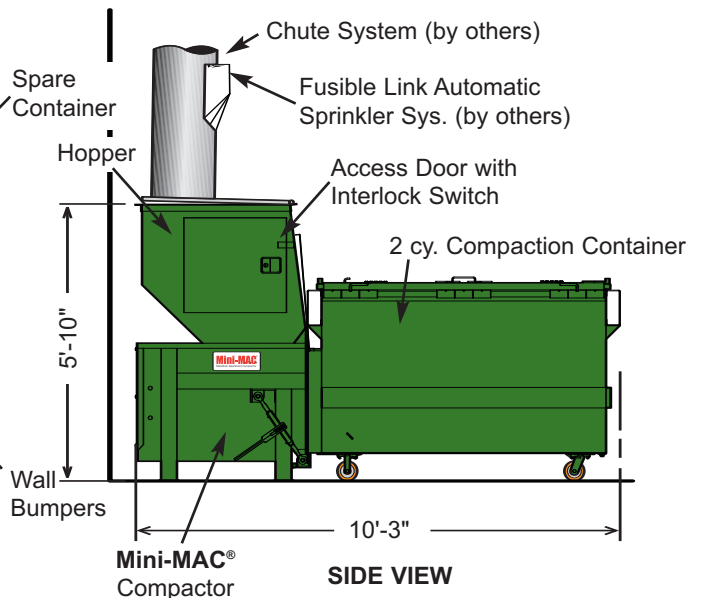

Visit our web site: www.MarathonEquipment.com



MARATHON EQUIPMENT COMPANY

P.O. Box 1798 • Vernon, AL 35592-1798 USA • (205) 695-9105 fax (205) 695-7250 **1-800-633-8974**
 130 Hwy. 339 • Yerington, NV 89447 USA • (775) 463-4030 fax (775) 463-4531 **1-800-624-5724**
 1102 Industrial Park Rd. • Clearfield, PA 16830 USA • (814) 765-0200 fax (814) 765-2072 **1-800-922-7062**

Pictures in this literature are illustrative only. Specifications are subject to change without notice in order to accommodate improvements to the equipment. Certified in compliance with ANSI Regulation Z245.2, all OSHA standards, and certified under WASTEC's Stationary Compactor Certification Program. Products must be used with safe practice and in accordance with said regulations and standards.

