

RJ-250SC-ET

Self-Contained Compactor/Container



The RJ-250SC-ET features an extra-wide ram, clear top opening (78" x 40") and low feed height (43 1/2").



General:

Charge Box Capacity		
(Mfrs. rating)	2.0 cu. yd.	1.53m ³
(WASTECH rating).....	1.4 cu. yd.	1.07m ³
Total Capacity	34 cu. yd	26m ³
Clear Top Opening.....	40" x 78"	1016mm x 1981mm
Loading Height	43 1/2" (feed at rear only)	1105mm
Overall Weight	12,700 lbs.....	5761 kg

Performance Characteristics:

Cycle Time.....	33 sec.	33 sec.
Total Normal Force	39,900 lbs.	178 kN
Total Maximum Force	49,500 lbs.	220 kN
Normal Ram Face Pressure	24.8 PSI.....	171 kPa
Maximum Ram Face Pressure	30.8 PSI.....	212 kPa
Ram Penetration	6"	152mm

Electrical:

Remote Power Unit	
Electrical Motor, 3/60/230-460.....	10 HP.....7.5 kW
Electrical Control Voltage	120 VAC
Panel Box Assembly UL Rated	
All Circuits Fused	
3 Push Button Station	Key Operated Start, Stop, Reverse

Hydraulic:

Hydraulic Pump	10 GPM	37.9 L/min.
Normal Pressure	1850 PSI	128 bar
Maximum Pressure	2300 PSI	159 bar
Hydraulic Cylinder (2)	Bore 4", Rod 2 1/2"	102mm, 63.5mm

Compactors



Front View

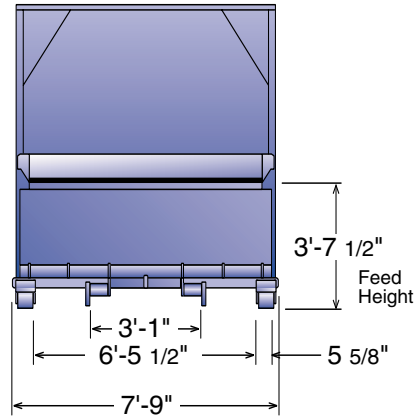

*Units as shown are not ANSI compliant. To be ANSI compliant, unit must have:

- A. Totally enclosed hopper with interlock switch, or
- B. Sustained manual pressure control ("Hold To Run" Button), or
- C. Special extended hopper designed to prevent reaching into charge box.

Top View

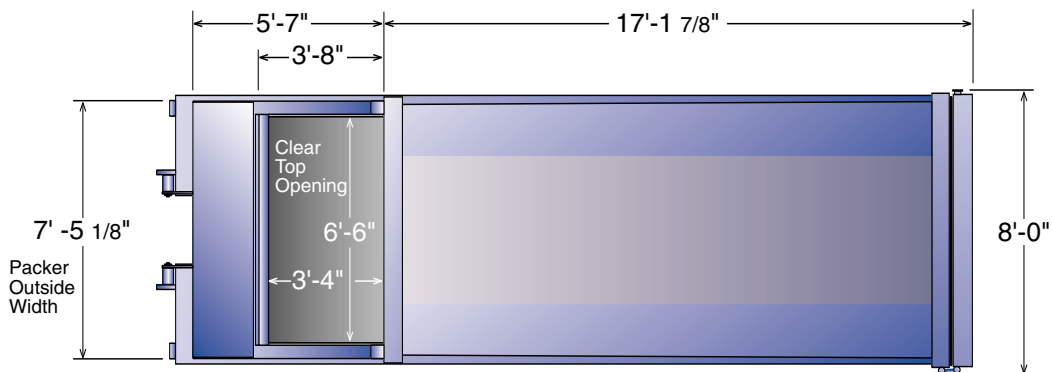

Side View

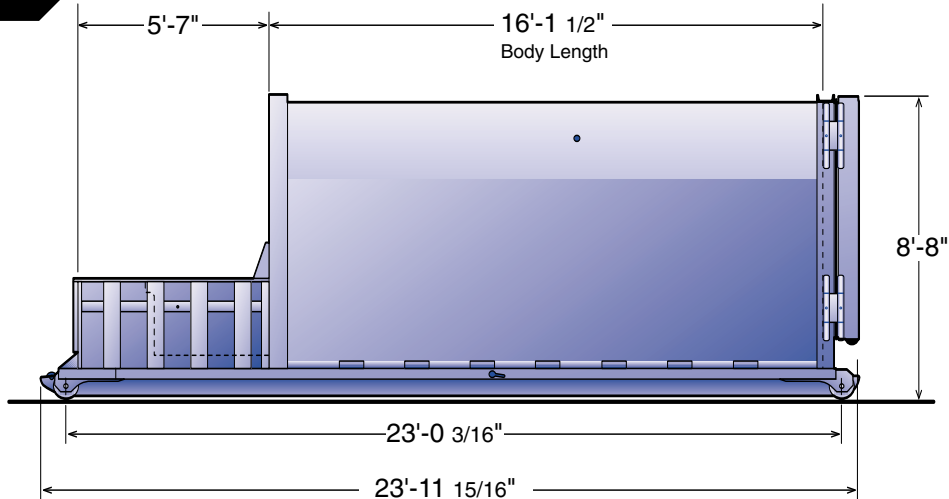

MARATHON EQUIPMENT COMPANY

P.O. Box 1798 • Vernon, AL 35592-1798 USA • (205) 695-9105 fax (205) 695-7250 1-800-633-8974
 130 Hwy. 339 • Yerington, NV 89447 USA • (775) 463-4030 fax (775) 463-4531 1-800-624-5724
 1102 Industrial Park Rd. • Clearfield, PA 16830 USA • (814) 765-0200 fax (814) 765-2072 1-800-922-7062

Visit our web site: www.MarathonEquipment.com



Pictures in this literature are illustrative only. Specifications are subject to change without notice in order to accommodate improvements to the equipment. Equipment must comply to ANSI Z245.2 standards. Products must be used with safe practice and in accordance with said regulations and standards.