

APARTMENT STYLE COMPACTORS



Mini-M.A.C.®

Apartment Compactor

The **Mini-M.A.C.** apartment compactor is a small, yet powerful compactor that can fit in areas where space is limited, such as trash rooms of apartment and high-rise buildings. It is commonly used in conjunction with a chute-feed system in multi-storied buildings.



Mini-M.A.C.® Features

- ▼ Up to 4:1 compaction ratio over uncompacted waste receptacles
- ▼ Remote power unit
- ▼ Convenient single-side ratchet
- ▼ Push-button controls mounted in the panel box face
- ▼ Hopper with access door and interlock for hand-feed or chute-feed applications
- ▼ Photoelectric cycle control
- ▼ Full container light
- ▼ CYCON Life-Xtender™ Cyclic Control System that offers reliable, solid-state circuitry eliminating pressure and limit switches



APARTMENT STYLE COMPACTORS



Mini-M.A.C.[®]

Dimensions and Specifications

Specifications	Model 3A		Model 5A	
Clear-Top Opening (L x W)	22 1/2" x 28"	572mm x 711mm	22 1/2" x 28"	572mm x 711mm
Compactor Capacity	0.30 yd ³	0.23 m ³	0.30 yd ³	0.23 m ³
Ram-Face Size (W x H)	30" x 20"	762mm x 508mm	30" x 20"	762mm x 508mm
Compactor Weight	1,600 lbs.	726 kg	1,600 lbs.	726 kg
Performance Characteristics				
Cycle Time	21 sec.		14 sec.	
Total Normal Force	13,900 lbs.	6305 kg	13,900 lbs.	6305 kg
Total Maximum Force	16,400 lbs.	7439 kg	16,400 lbs.	7439 kg
Normal Ram-Face Force	23.2 psi	160 kPa	23.2 psi	160 kPa
Maximum Ram-Face Force	27.3 psi	188 kPa	27.3 psi	188 kPa
Ram Penetration	4"	102mm	4"	102mm
Electrical Equipment				
Electric Motor 208/230/460/575 3-Phase	3 hp	2.2 kW	5 hp	3.7 kW
Electric Control Voltage	120 VAC			
Standard Controls Include	Three-Push Button Station: Keylock Start/Stop/Reverse			
Hydraulic Equipment				
Hydraulic Pump Capacity	4 gpm	15.1 L/min	6 gpm	22.7 L/min
Maximum System Pressure	1,950 psi	134 bar	1,950 psi	134 bar
Hydraulic Cylinder(s)	1		1	
Bore	2 1/2"	64mm	2 1/2"	64mm
Rod	1 1/4"	32mm	1 1/4"	32mm
Stroke	18 1/2"	470mm	18 1/2"	470mm

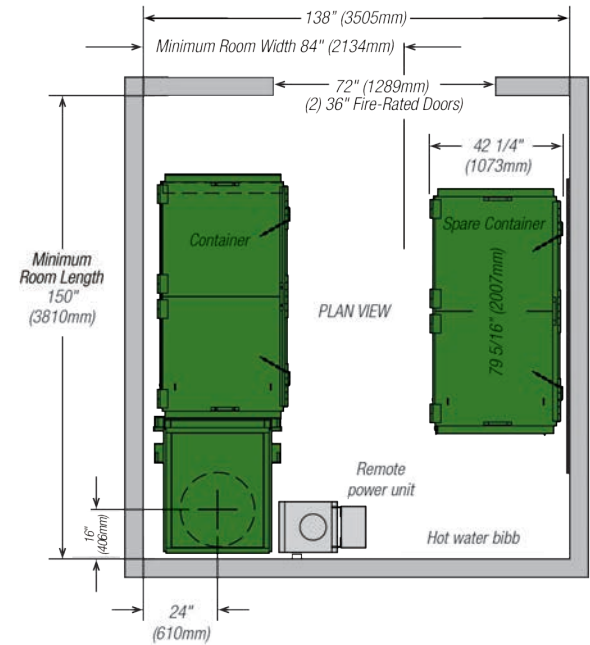

Typical Mini-M.A.C. Model 3A compactor configuration with chute system

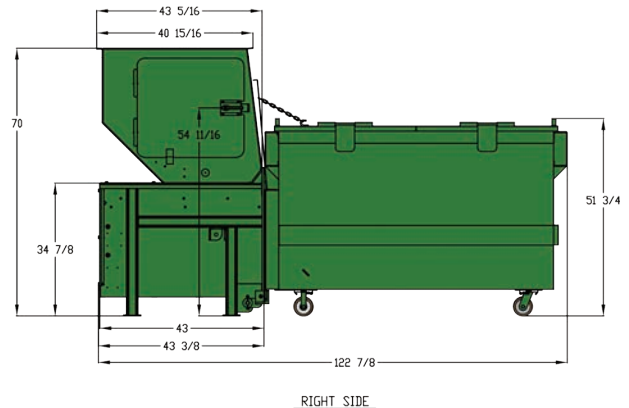

RIGHT SIDE

Additional Features of the 3A & 5A Models: Standard Chute Feed Hopper with (left hand or right hand) Access Door & Interlock; Photocell Package which includes Start-Up Alarm; Advanced Warning; Container Full; and Auto Shut-down.

Pictures and mechanical diagrams in this literature are illustrative only and may not be to scale. Specifications are subject to change without notice in order to accommodate improvements to the equipment. Certified in compliance with ANSI standard Z245.2 and all applicable OSHA Regulations. Products must be used only by trained operators in accordance with the Operator Manual, as well as applicable regulations, laws, and ANSI standards.

We're Here To Help!

For detailed specifications, recommendations, or to request a site survey comparing various systems, contact the Marathon[®] Sales Team at MarathonSales@MarathonEquipment.com

Authorized Dealer:

Compactor & Baler Rental and Leasing Programs Available!



Sourcewell

Awarded Contract

Contract # 040621-MEC



Marathon Equipment Company | P.O. Box 1798 | Vernon, AL 35592-1798

Learn more about Marathon Equipment: 800.633.8974 | www.marathonequipment.com