

COMPACTOR OPTIONS



RamJet Options

For unique installation requirements



Compactor Options

- ▼ Container-fullness measuring system
- ▼ Cycle-control systems
- ▼ Power pack options
- ▼ Odor-control options
- ▼ Hoppers
- ▼ Doghouses
- ▼ Security chutes
- ▼ Walk-on treadplates

The Worldwide Compaction Leader

Marathon® Equipment is known throughout the world as one of the leading manufacturers of quality on-site waste compaction products. The RamJet® brand has been the industry standard for quality and innovation for more than 50 years, and includes stationary and self-contained compactors, compaction containers, apartment and high-rise compactors, pre-crushers, auger-style compactors, transfer systems, and a wide array of options for virtually any application.





RamJet Options

For unique installation requirements

The perfect configuration for your specific needs

Options are an essential part of virtually any compactor installation. Whether the options are for safety issues, convenience, operation efficiencies, or monitoring systems, waste-handling equipment can be fitted with a variety of customizable features to meet the demands of the application. Marathon® compactor options include several categories such as: container-fullness measuring systems, usage-measurement systems, cycle-control systems, power pack options, odor-control systems, and steel options.

Container Fullness and Usage Measurement Systems

The revolutionary remote monitoring system enables the remote monitoring of compaction equipment, right from any desktop or mobile device using integrated wireless communications. The system combines on-site factory built-in or external add-on hardware with an industry-leading software platform to provide, real-time compactor data, 24 hours per day, seven days per week.



Remote monitoring provides users with the tools to optimize equipment, and measurably reduce waste management costs. Eliminate unnecessary pickups, and service equipment to lessen unscheduled downtime, and substantially reduce your overall carbon footprint.



The **Advance-Warning Light** or **3/4-Full Light**, automatically senses the hydraulic system pressure. When the pressure is within 200 psi of normal shutdown pressure, the light, which is built into the push-button station, will flash intermittently and the packer continues to operate normally.

The **Full-Container Light** option illuminates to indicate when the container is full. The light, which is built into the push-button station, is activated when the unit reaches normal shutdown pressure and the compactor automatically stops. To reactivate the compactor for normal operation, it's necessary to empty the container and depress the Full-Container Light to reset the Full-Container Light circuit.

Conduit is used to carry all external wiring on Marathon Compactors.

A **Pressure Gauge** option indicates the compactor's system pressure and enables the operator to determine when the container is approaching its "packed out" state. It can be mounted adjacent to the compactor's control station or mounted on the power unit if a remote power pack is used. A **Dual Needle-Pressure Gauge** with an adjustable needle to mark readings is also available.



RamJet Options

For unique installation requirements

Cycle Control Systems

The **Photoelectric Cycle Control** consists of a light source and a reflector. When the light beam has been interrupted for approximately 15 seconds, it will automatically activate the packer, which will continue running until the obstruction between the light source and reflector is cleared. The kit can be mounted on a hopper on parallel walls opposite one another. Two holes should be added to properly locate the photo eye and reflector. This mounting arrangement keeps the photoelectric eye and reflector cleaner and reduces the chance of accidental mis-alignment while in use. The light source is LED and, therefore, the beam is not visible. It will, however, penetrate dust and carry over a longer distance than the conventional light bulb. A start-up alarm is required and is included in this option.

Automatic Shutdown is included for the Photoelectric Cycle Control, Start-Up Alarm, and Container-Full Light options. It prevents extended continuous packer operation due to a “blocked” photoelectric eye, thereby avoiding unnecessary wear and tear on the packer due to heat buildup. The option package includes a timer that can be set for up to 30 minutes (for high-rise applications, 15 to 30 minutes is recommended), an illuminated push-button so the operator knows why the unit has shut down, plus other completing parts. To deactivate the timer, an operator depresses the illuminated push-button after clearing the blockage.



Sonic Sensors function like the Photoelectric Cycle Control, but feature sonar-based sensors for dusty environments.



The **Jog-Control Station** enables manual compactor operation. It consists of a three-position key switch: Remote, OFF, and Bypass, and a three-position selector switch: Ram Extend, OFF, and Ram Retract. The key switch is normally left in the “Remote” mode. In that position, the remote push-button station can be operated, but the Jog Control Station is deactivated. When the container is to be emptied, the driver’s key is inserted and the switch rotated to the “Bypass” mode, which permits the driver to manually control the packer in order to clear refuse left in the charge box. If the container will be absent for a period of time, the key switch can be rotated to “OFF” position, which deactivates all controls and prevents cycling the unit while the container is not present. This option is particularly useful for chute-fed installations where access into the building is difficult. It is mounted on the charge box end of the packer (RH standard, if LH desired, it must be specified.)

The **Hold-To-Run Button** or Sustained Manual Pressure Control Button requires the compactor operator to remain at the remote push-button station while the compactor is in use and may be required to meet ANSI standards in certain applications. Actuation requires depressing the “Hold To Run” after the “Start” button is released. If the “Hold-To-Run” button is released, the unit will shut off.

The **Multi-Cycle Timer** controls automatic operation of the compactor. When the “Start” button is depressed, the compactor will operate for a preset number of cycles. The timer is preset by Marathon[®] at three cycles and can be adjusted by the user.

The **Programmed Timer** can be adjusted from three to 30 minutes to automatically start the compactor. This option is desirable when the compactor is conveyor fed or when the refuse is fed to the compactor at a predictable rate. The Programmed Timer includes a three-position selector switch for Automatic, OFF, and Manual modes. This option is included with a container-full light and start-up alarm.



COMPACTOR OPTIONS



RamJet Options

For unique installation requirements

Power Pack Options

In applications with duty cycles over 50%, the power unit should be equipped with an **Oil Cooler**. The Oil Cooler includes a circulation pump and a heat exchanger to control oil temperature.

A thermostatically controlled **Oil Heater** can be installed for better cold-weather performance. It is installed on the oil reservoir and is equipped with a manually adjustable thermostat control so that the heater functions only when required. It does not have to be disconnected during the summer months. Its temperature range cannot exceed 100° F.



Odor Control Systems

The **Ozone Odor Control System** generates ozone, a powerful oxidizer that breaks down odor molecules and converts them into water vapor and other odorless, harmless gases. In addition to eliminating odors from the air, the ozone-rich atmosphere inhibits germ and bacteria growth. The system requires no chemicals or fragrances and only incidental, routine service. Some Ozone units may require a separate 110 volt power source.

Hoppers

Hoppers can be designed to best direct waste into the compactor and reduce hazards. Marathon **Side-Feed** and **Rear-Feed Hoppers** meet ANSI and applicable OSHA standards.

The **Three-Sided, Side-Feed Hopper** is designed for loading material from ground level by hand, forklift, or with a cart dumper system. These can be configured for left- or right-side loading.

The **Three-Sided, Rear-Feed Hopper** can also be fitted with a **Hinged Access Gate** for dock-loading applications. It can also be used with **Treadplate Top Cover** and **Hand/Toe Rails** to conform to OSHA and ANSI standards. The Three-Sided, Rear-Feed Hopper requires either the Hinged Access Gate with interlock switch or a sustained manual pressure control.

The **Access Interlock Switch** is mounted on the security-door frame or access gate through which refuse is fed into the packer. It prevents operation of the packer while the door or gate is open.



For more information or to order, call 1-800-633-8974 or visit us at www.marathonequipment.com

COMPACTOR OPTIONS



RamJet Options

For unique installation requirements

Hoppers (Continued)

The **Treadplate Top Cover** is secured to the top of the packer in lieu of the standard cover. The diamond pattern treadplate is available in either 700-lb. or 8,000-lb. capacity.

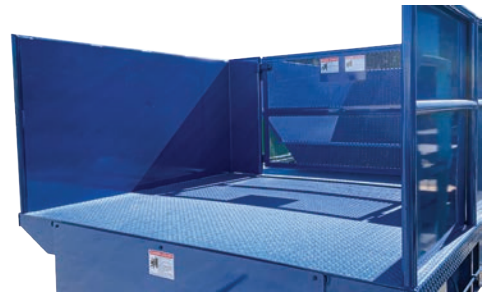

The **Four-Sided, Rear-Feed Hopper** is for dock-loading applications and eliminates the need for an access gate, interlock switch, and the “hold to run, release to stop” button on Marathon self-contained compactor/containers. A **Tread Plate** with hand and toe rails may be required on some compactors.



The **Hinged Breaker Bar Retainer Teeth** help prevent clutter in the charge box caused by “memory” and springback of some types of material such as corrugated cardboard. As the ram retracts, the teeth engage the material to keep it in the container. Teeth are hinged so that material can pass beneath them without undue stress on the breaker bar.



The **Rear-Feed Hopper with a Counterbalanced Lid** is ideal for dock-loading applications with a lid that totally encloses the hopper opening and requires minimum effort to open and close.

*Rear-Feed Hopper
With Counterbalanced Lid*

Qwik Clean Door

The Qwik Clean® door on the packer end makes cleaning out behind the ram-in-cylinder area a snap. The door has miniature hinges, a door seal, and a ratchet binder. Also, featured is the RamJet® rear-feed doghouse door option.

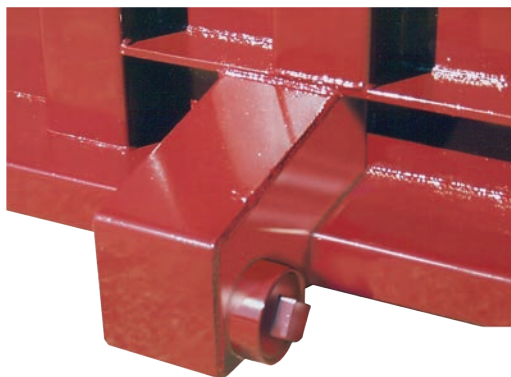

StreamLine Option

The StreamLine® option enables excess liquid to be drained from the container, reducing net-payload weight, and significantly reducing hauling costs. Liquid is routed to four interconnected 4" drain outlets, located at each corner of the StreamLine unit. Connection can be made to a hose, piping, or a pump.

* Do not discharge onto ground or into storm water drains. Always ensure liquid wastes are managed in compliance with applicable laws.



For more information or to order, call 1-800-633-8974 or visit us at www.marathonequipment.com

COMPACTOR OPTIONS



RamJet Options

For unique installation requirements

Platforms and Container Guides

The **Expanded Metal Steps/Platform** with Hand-and-Toe Rails for the VIP is used with rear- or side-feed 8 yd. V.I.P. Vert-I-Pack® applications. The expanded metal steps maximize traction by enabling mud or snow to pass through the grating.

The **Container Guide** is designed for anchoring to a concrete pad and greatly facilitates compactor/packer alignment. 15' Container Guides are recommended for use with self-contained compactors.

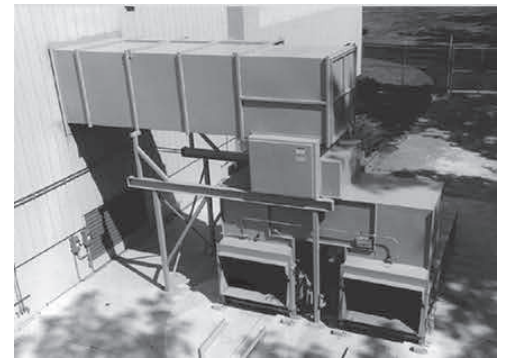
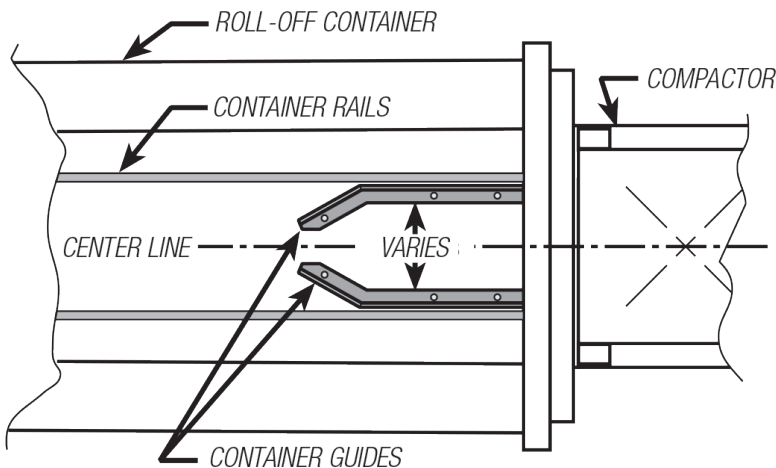

Security Chutes

Marathon offers several standard chute systems and will also construct custom configurations to suit your installation requirements.

Gravity-feed chutes must have a vertical latitude above the height of the compactor.

Security chutes are constructed of 11-gauge high-tensile steel. The optional **Security Door** is furnished as a completed assembly and consists of an outside and inside architectural trim, and a steel collar that passes through the wall, accommodating wall thicknesses up to 14". The latch is available with a lock if desired.

Security Chutes provide improved security by enabling employees to access the compactor without being exposed to weather, reducing pilferage, and helping to maintain a secure environment.

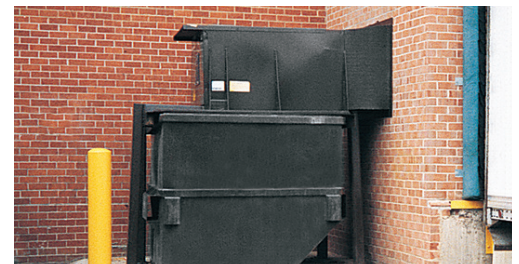

Side-Feed Security Chute



Rear-Feed Security Chute



For more information or to order, call 1-800-633-8974 or visit us at www.marathonequipment.com

COMPACTOR OPTIONS



RamJet Options

For unique installation requirements

Doghouses

Marathon Stationary or Self-Contained Compactors equipped with a **Doghouse with Side Door** are ideal for ground-loading applications. This type of hopper offers a totally enclosed charge box and a lockable door latch for added control and security, as well as an access interlock. The door can be placed on the left, right, or both sides for convenient loading.

A **Doghouse with Rear Door** on a Marathon Roll-Off Self-Contained is ideal for applications where the unit is picked up at the packer end and space limitations may prevent loading from the side.

The **Rear-Feed Barn Door-style Doghouse** is suitable for dock-feed applications. It can be used on the Dual Recycling Compactor (DRC II) when two separate feed openings are required.

The **Mailbox-Style Doghouse** is a Marathon innovation, ideal for apartment complexes and convenience centers. The hopper door pulls down similar to a mailbox for loading. The compactor automatically cycles after the hopper door has been opened and closed (number of times specified by customer).



The **Telescoping Chute/Doghouse** is another Marathon innovation that was designed for self-contained compactors installed in an enclosed space. The chute "telescopes" out for loading and retracts for transport to the landfill. The chute extends to the wall of the enclosure. Tenants load waste through an access door on the outside of the enclosure.



Manual Doghouse Latch

Cart Dumpers/Tippers

Marathon offers a variety of Ground-Level and Dock-Level Cart Dumpers. They can be installed in a number of configurations. The RJ-250SCWD Self-Contained has an integral cart dumper with three-sided hopper.

The Bayne Thinline® Compactor-Mounted Container Dumper for 90-gallon containers, shown on an Marathon RJ-250SC, increases convenience and

productivity (below). Container Dumpers can also be used with a variety of self-contained stationary compactors.



*RJ-250SCWD With
Integral Cart Dumper*



*RJ-250SC With Bayne®
Thinline® Compact Container
Dumper*



For more information or to order, call 1-800-633-8974 or visit us at www.marathonequipment.com

COMPACTOR OPTIONS



Compactor Options

Dimensions & Specifications

Electrical Data – Fuse and Circuit Breaker Chart Full Dual Element					
Motor HP	Volts	Load Amps	Fuse Max Size	Circuit Breaker	Service Disconnect Amps
3 HP	3/208	10.6	20	25	30
	3/230	9.6	15	20	30
	3/460	4.8	10	15	30
	3/575	3.9	10	15	30
5 HP	3/208	16.7	30	40	30
	3/230	15.2	25	40	30
	3/460	7.6	15	20	30
	3/575	6.1	10	15	30
10 HP	3/208	30.8	50	80	60
	3/230	28.0	50	70	60
	3/460	14.0	25	35	30
	3/575	11.0	20	30	30
15 HP	3/208	46.2	80	90	100
	3/230	42.0	70	90	100
	3/460	21.0	35	40	60
	3/575	17.0	30	40	30
20 HP	3/208	59.4	100	125	100
	3/230	54.0	90	125	100
	3/460	27.0	45	60	60
	3/575	22.0	35	50	60
30 HP	3/208	88.0	150	225	200
	3/230	80.0	150	200	200
	3/460	40.0	70	100	100
	3/575	32.0	60	80	60
50 HP	3/208	143.0	250	350	400
	3/230	130.0	225	300	400
	3/460	65.0	110	150	200
	3/575	52.0	90	125	100

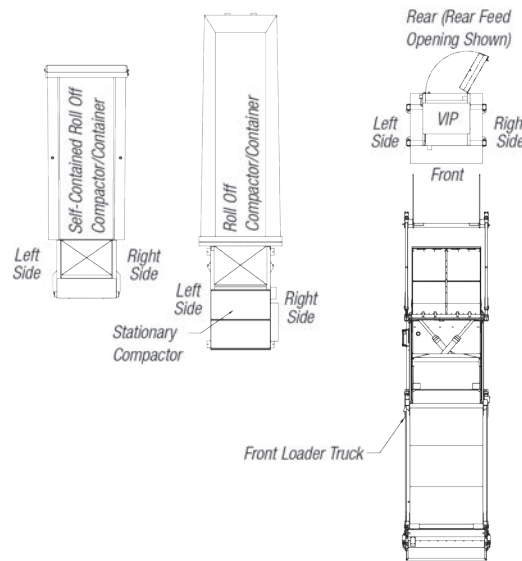
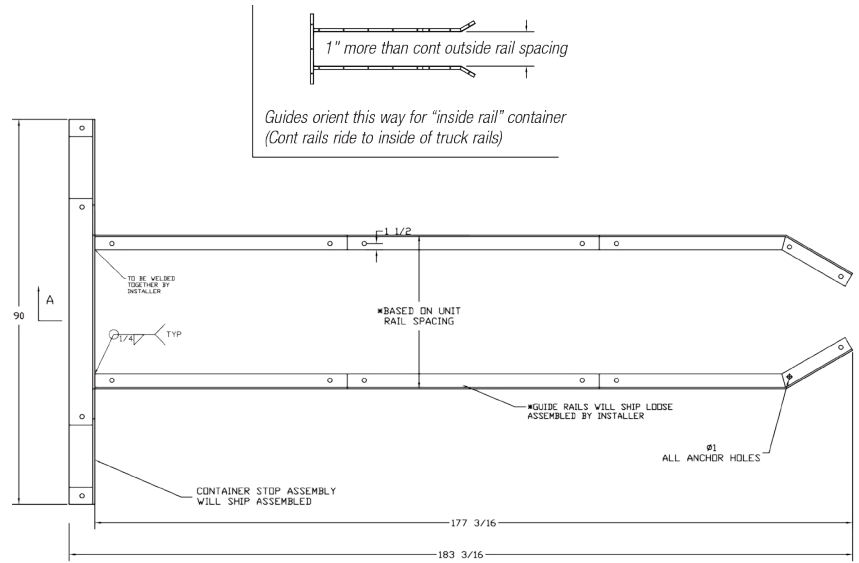

Pictures and mechanical diagrams in this literature are illustrative only and may not be to scale. Specifications are subject to change without notice in order to accommodate improvements to the equipment. Certified in compliance with ANSI standard Z245.2, all applicable OSHA Regulations. Products must be used only by trained operators in accordance with the operator manual, as well as applicable regulations, laws, and ANSI standards.

We're Here To Help!

For detailed specifications, recommendations, or to request a site survey comparing various systems, contact the Marathon Customer Care team at: **800.633.8974**

Authorized Dealer:



Marathon Equipment Company | P.O. Box 1798 | Vernon, AL 35592-1798

Learn more about Marathon Equipment: 800.633.8974 | www.marathonequipment.com

© 2025 Marathon Equipment Company. All rights reserved.